



TURN AISLES INTO **PROFITS**

Pipp's **Rolling Benches** boost profitability by eliminating fixed aisles and unlock up to 50% more grow space. Custom-built in multiple sizes, the easy-roll bench tops extend for full access, while corrosion-resistant aluminum construction and anti-tip brackets ensure durability and safety. With quick installation, adjustable heights, and flexible top options, Rolling Benches maximize efficiency, output, and long-term reliability.

50% more production space

15-20 lbs/ft² loading capacity

Quick and easy installation

System Features

- Snap-together fittings
- All-aluminum frame
- Threaded rods allow for up to 5" of vertical adjustment
- 2" diameter rolling tubes allow for smooth travel
- Optional trellis frames
- Compatible with both ebb and flow trays and expanded metal benchtops

System Specifications



Available Widths & Travels

- 4' wide: 16" travel
- 5' wide: 20" travel



Loading Capacity

15-20 lbs/ft² loading capacity, based on configuration

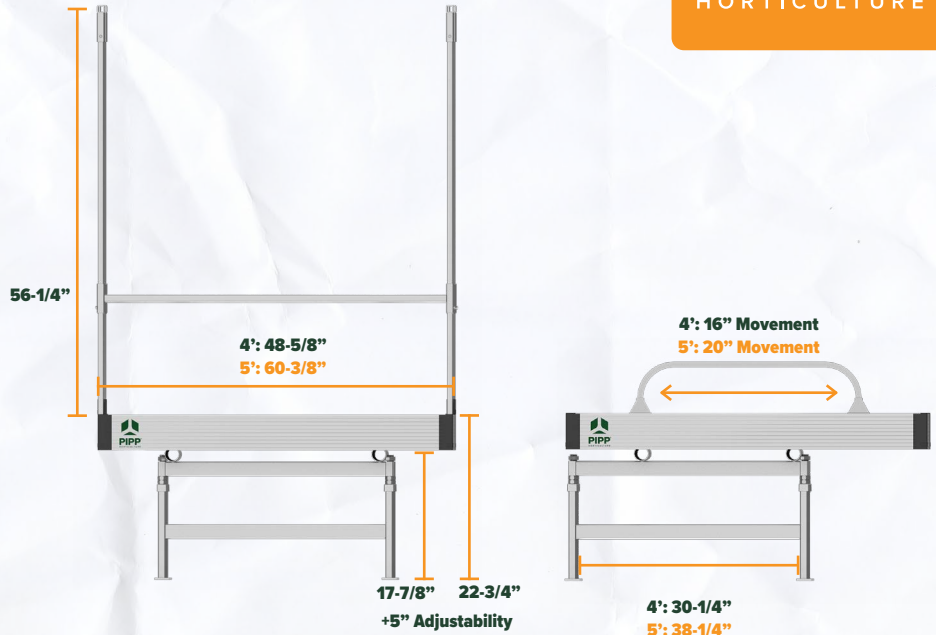

System Improvements

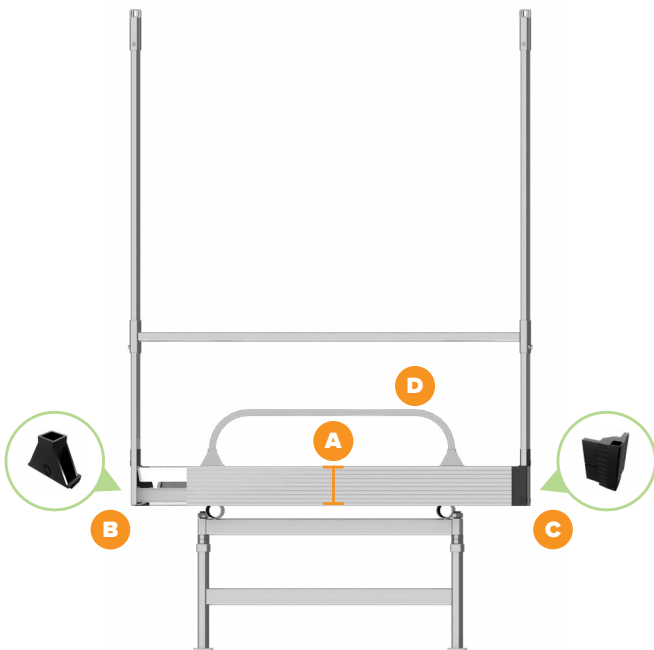

Refined for Maximum Efficiency

4.87" High Side Rail

- Decreased from 5.5"
- Allows for easier plant access
- Efficient use of material
- In-line splice

Re-Engineered Trellis Supports

- Stronger, snap-in-place design
- Don't overhang the trays or interfere with the plants
- Built-in drainage

Redesigned Corners

- Integrate with trellis posts

Handle

- Optional pull handle